

A COMPREHENSIVE REVIEW ON AI-BASED FARMING ROBOTS

R. R. Mali^{1*}, V. B. Phulwale², A. B. Phad³, P. S. Pote⁴, R. S. Puri⁵

^{1,2,3,4,5}Mechanical Department, Sinhgad College of Engineering, Pune, India

Abstract

The integration of technology and automation with traditional farming methods heralds a transformative era for modern agriculture. The spirit of this agricultural revolution is embodied in this project, Design & Development of an Integrated Farming System for Seed Sowing, Pesticide Application, and Seed Replantation with Post-Sowing Assessment. This concept offers a novel solution to the urgent need for more food production in the world while also addressing environmental sustainability. The technology being developed aims to provide a comprehensive solution to revolutionize traditional farming. This project is much more important than just automation. From resource conservation and environmental preservation to economic viability and food security, it tackles important issues in agriculture. Through increased productivity and sustainability, this integrated farming system has the potential to completely transform the agricultural landscape and usher in a more promising and secure future for the world's food production. An overview of the project's main goals and how it can change agriculture in the future can be found in this paper.

1. Introduction

Received:25.07.2024; Accepted:07.09.2024

Keywords: Image processing, Replantation, Seed Sowing, Post Sowing Assessment.

*Corresponding author name and email: R. R. Mali, rrmali.scoe@sinhgad.edu

How to cite this article: R. R. Mali, V. B. Phulwale, A. B. Phad, P. S. Pote, R. S. Puri, A comprehensive review on AI-based farming robot, KT Journal of Mechanical Engineering, 1, 2024,28-35. <https://doi.org/10.64188/3048956325004>

Conventional seed planting is a labour-intensive process that takes a lot of time and human labour. Farmers can save time and costs by reducing the need for manual work by automating this procedure. Unequal seed dispersal from manual sowing might lead to unequal crop development. Large-scale seed distribution is accurate and consistent thanks to the automated method, which promotes steady plant growth and increased yields. Utilizing a well-engineered robotic system, the project maximizes the utilization of resources like soil and seeds. By precisely sowing seeds into the soil, it prevents waste and increases resource efficiency. By using precision spraying techniques, the number of pesticides used overall is decreased by focusing on the precise locations that need to be treated. This method reduces the careless use of chemicals, which supports environmental sustainability. The project increases resource efficiency and minimizes manual intervention, which supports sustainable agriculture. It reduces farming's negative environmental effects, supporting the global movement toward environmentally responsible farming methods.

2. Literature Review

Yogesh Ramdas et al. (2014), introduce the concept of utilizing automation, specifically an Arms Controller, for managing green growth. While this paper primarily focuses on plant growth, it underscores the significance of automation in agricultural applications. D S Suresh et al. (2013) present an innovative device for soil testing, illustrating how automation can streamline critical tasks in agriculture. Automated soil testing is a fundamental aspect of precision agriculture, allowing farmers to tailor their soil management practices for optimal crop growth. Prema, Kumar, and Sunitha (2009), delve into the broader field of automation and control but underscore its relevance in agriculture. The concept of online temperature control based on virtual instrumentation can be adapted to agricultural applications, ensuring optimal growing conditions. Weatherhead (2002), demonstrates the potential for robotics in agriculture. While focused on tree climbing, it highlights the adaptability of robotic systems for agricultural tasks that involve precision and automation. Ankit Singh and Abhishek Gupta, (2015), research is particularly relevant as it directly addresses agricultural automation. The paper discusses the development of an "Agribot," showcasing the possibilities of automation in various farming activities. Patrick Piper and Jacob Vogel, (2015), in their work they explored the creation of an autonomous soil monitoring robot. This paper illustrates how automation can be harnessed for soil assessment, a critical component of precision agriculture. Mohammad Rezwanul Huq, et al. (2019), explain how IOT can be used in the agricultural sector to perform various actions using robots, which include designing of the robots and their programming. Niraj Doshi, et al. (2017), explain in theory about the various types of actions that can be done by robots in the agriculture field and overall increasing its efficiency to give maximum efficient output. Vinayaka N. Hallur, et al., (2018), researched on agriculture monitoring system by using image processing technique that helped to identify the lack of any component and after analysing a proper action can be taken Nagabhushana et al., (2017), This study delves into the design and practical implementation of an agricultural system driven by

IoT sensors. It may discuss the challenges faced, methodologies applied, and outcomes achieved in deploying IoT-based solutions in agricultural contexts.

Khedekar et al. (2016) offer a comprehensive overview of precision agriculture techniques on a global scale. It likely covers advancements in precision farming, incorporating GPS technology, satellite imagery, and data analysis to optimize farming practices, conserve resources, and maximize yields. Abhilash et al. (2018), This paper likely investigates the design and development of an affordable smart agriculture system. It may emphasize the importance of cost-effective solutions in making IoT technology accessible to small-scale farmers, enabling them to benefit from modern agricultural practices. Prasanna et al., (2015). Focusing on wireless sensor networks, this study explores their applications in agricultural field monitoring and automation. It might discuss real-time data collection, environmental sensing, and remote monitoring, showcasing how wireless sensors enhance decision-making processes for farmers. Kumar et al., (2015), This review likely provides insights into precision agriculture strategies for improved crop production. It may cover technologies such as soil sensors, variable rate technology, and remote sensing, emphasizing their roles in sustainable farming, resource management, and yield optimization. Hossain et al., (2018), This research presents a smart farming system designed to monitor and control environmental conditions. It explores the utilization of advanced sensors and computer science techniques to collect and analyze data related to soil quality, climate, and crop health. The paper likely discusses the significance of real-time data in decision-making, enabling farmers to optimize resources and improve agricultural outcomes. Lowe D. G., (2004), In this paper, the Scale-Invariant Feature Transform (SIFT) algorithm was introduced, providing a method for detecting and describing local features in images, making it robust to scaling, rotation, and affine transformations. Dalal, N., & Triggs B., (2005), This paper proposed Histograms of Oriented Gradients (HOG) as a feature descriptor for human detection, which has been widely used in pedestrian detection systems. Liu, C., Yuen, J., & Torralba, A. (2011), This paper introduced the SIFT Flow algorithm, which establishes dense correspondences between images, enabling applications in image editing, object recognition, and scene parsing. Girshick, R., Donahue, J., Darrell, T., & Malik, J. (2014). This paper introduced the Region-based Convolutional Neural Networks (R-CNN) framework, which significantly improved object detection accuracy using deep learning techniques. He, K., Zhang, X., Ren, S., & Sun, J. (2016). The ResNet architecture presented in this paper has significantly advanced the capabilities of deep neural networks, enabling the training of extremely deep networks with improved performance. Redmon, J., Divvala, S., Girshick, R., & Farhadi, A. (2016) YOLO (You Only Look Once) introduced an efficient object detection model capable of real-time performance, making it widely adopted in applications requiring low-latency object detection. Zhang, H., Xu, T., Li, H., Zhang, S., Wang, X., Huang, X., & Metaxas, D. N. (2018). This paper presents the StackGAN++ model, which demonstrated impressive results in generating high-resolution and realistic images using Generative Adversarial Networks (GANs) [23-26].

3. Methodology

Our goal is to create an advanced technology that can evenly and precisely plant seeds across a huge area. This helps to ensure uniform plant distribution and reduces the labor-intensive part of hand sowing, both of which eventually lead to increased yields.

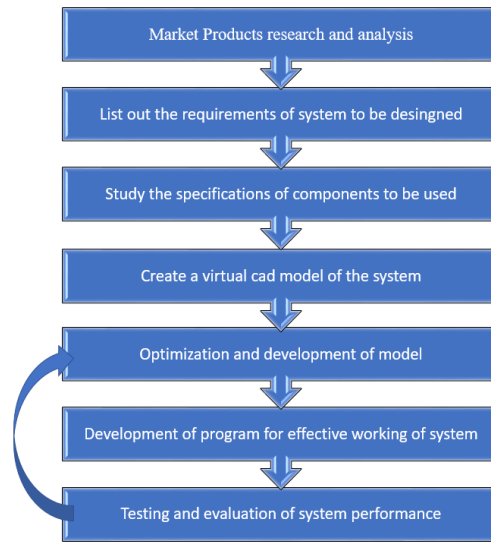

Flowchart 1

Optimal Use of Pesticides: Protecting crops from pests and diseases is a major function of pesticides. However, the ecosystem may suffer if they are used carelessly. To minimize pesticide usage and preserve crop health, our system will use precision spraying techniques to target specific areas that require treatment.

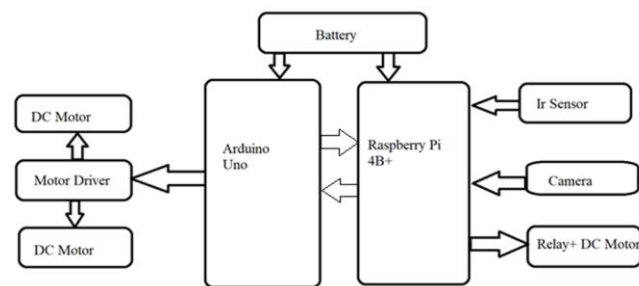

Figure 1. Block Diagram

Automatic Replanting of Seeds: If germination is uneven or unsuccessful, proposed system will automatically detect and replant seeds in areas that do not exhibit sufficient growth. This characteristic guarantees that no arable land is left unused, maximizing crop yield and overall productivity. [1]

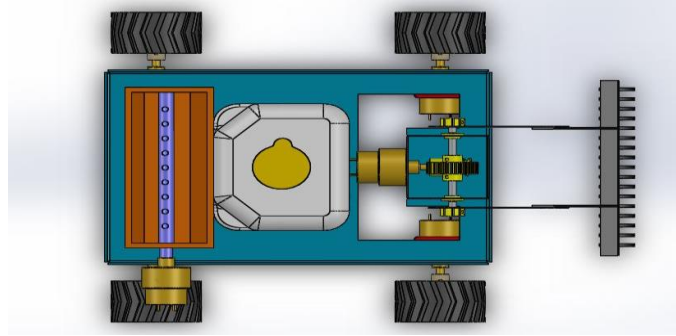

Figure 2. Model image

It is suggested to automate this operation by designing and building a fully automated seed-sowing robot. Four motors are used by the suggested robot to move it in the desired directions. We deposit seeds into a little bracket. The robot has a funnel-like design that allows it to transfer seeds into a lower container. There, we pick up a set number of seeds using a shaft equipped with bucket-tooth gears and evenly distribute them across the ground in the right amount. A bent plate that drags on the ground to create a slot ahead of the machine before seeds are placed in it can be added to the robot's front. The robot's back can be equipped with a bent rod that resembles a tail, which is used to cover the seeds with soil by pouring soil over them. Thus, the system used a well-engineered mechanical robotic system to fully automate the process of spreading seeds. It will reevaluate using a machine learning algorithm through image processing after five to ten days to assess if the seeds have grown into plants or not. If not, the seeds will be poured again in the same spot.

3.1 Components:

- a. **Raspberry Pi 4 B:** Description: Raspberry Pi is a credit-card-sized single-board computer developed for educational purposes. It features various input/output ports, including USB, HDMI, GPIO (General Purpose Input/Output), and camera interfaces. Use: Raspberry Pi serves as the brain of the automation system. It runs the control algorithms, processes data from sensors and cameras, and communicates with other components to coordinate the agricultural tasks.
- b. **Servo Motor:** Description: A servo motor is a rotary actuator that allows for precise control of angular position. It consists of a motor, gears, and a control circuit. Use: Servo motors are used for precise and controlled movement in robotics. In the project, they can control various mechanical parts, such as seed dispensers and pesticide sprayers, ensuring accurate and controlled actions.
- c. **IR Sensor (Infrared Sensor):** Description: IR sensors detect infrared radiation. They typically consist of an IR emitter and a receiver to measure the intensity of infrared light. Use: IR

sensors can be used for proximity sensing, obstacle detection, and line following in robotics. In the project, they can be employed for detecting obstacles or boundaries in the field.

- d. **Motor Driver L293D:** Description: L293D is a motor driver integrated circuit that allows the control of two DC motors in both directions (forward and reverse) with pulse-width modulation (PWM) capability. Use: Motor drivers like L293D are used to control the movement and direction of DC motors. They are vital for robotic systems where precise motor control is required, such as in the movement of the automated seed sowing robot.
- e. **LED (Light Emitting Diode):** Description: An LED is a semiconductor light source that emits light when current flows through it. Use: LEDs are used as visual indicators in electronic circuits. In the project, they can indicate the system's status, such as successful seed planting or completion of a task.
- f. **DC Motor:** Description: DC motors convert electrical energy into mechanical motion. Use: DC motors are used in robotics for various tasks, such as driving wheels, moving arms, and rotating sensors. In the project, they drive the mechanical parts of the automated system.
- g. **Image Detector:** Description: A camera captures still images or video footage. Use: Cameras are used for visual data acquisition. In the project, they capture images of the field, which are processed for tasks like seed placement, pest detection, and growth monitoring using image processing techniques. Each of these components plays a crucial role in the functionality and automation of the agricultural system, contributing to the overall efficiency and precision of the project.

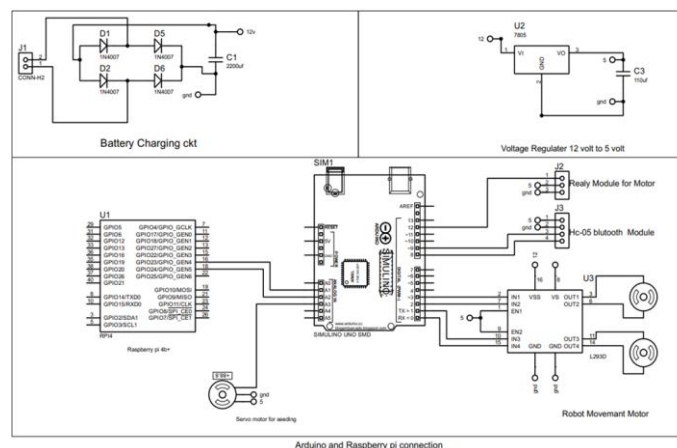

Figure 3. Circuit Diagram

4. Conclusions

The automation of seed sowing, pesticide application, and seed replantation should reduce the need for manual labor and save time for farmers. By precisely targeting seed placement and pesticide application, the system should optimize resource usage, reduce wastage, and maximize efficiency. Efficient seed sowing ensures uniform distribution, leading to consistent plant growth and ultimately higher yields. By avoiding the wastage of seeds and pesticides, the project will contribute to the conservation of valuable agricultural resources.

5. References

1. Green Growth Management by Using Arm Controller, B Yogesh Ramdas et al *Int. Journal of Engineering Research and Applications*, 4 (3), 2014, 360-363.
2. D. S. Suresh, Jyothi Prakash K V, Rajendra C J, Automated Soil Testing Device, *ITSI Transactions on Electrical and Electronics Engineering (ITSI-TEEE)* 1(5), 2013, 1-10.
3. K. Prema, N. Senthil Kumar, and K.A. Sunitha, Online Temperature Control Based on Virtual Instrumentation, *IEEE, International Conference on Control, Automation, Communication and Energy Conservation*, 2009, Perundurai, India, 4-6 June, 2009.
4. Weather head published a paper on, "an autonomous tree climbing robot utilizing four bar linkage system" (CIGR-2002).
5. Ankit Singh and Abhishek Gupta published a paper on "agribot" (IJARCCE-2015).
6. Patrick Piper and Jacob Vogel published a paper on "Designing an Autonomous Soil Monitoring Robot" (IEEE - 2015).
7. Mohammad Rezwanul Huq, Development of a Smart Agriculture System Using IoT Technology, *International Conference on Robotics, Electrical and Signal Processing Techniques (ICREST)*, 2019.
8. Niraj Doshi, Automation in Agriculture Using Drones and Robotics: A Review, *International Journal of Engineering and Computer Applications*, 2017, 1-7.
9. Vinayaka N. Hallur, Automated Agriculture Monitoring and Control System, *International Journal of Engineering and Computer Applications*, 2018.
10. S. Nagabhushana, Design, and Implementation of a Smart Agricultural System Based on IoT Sensors, *International Conference on I-SMAC*, 2017
11. R. Khedekar, Precision Agriculture –A Worldwide Overview", *International Journal of Advanced Engineering Research and Science (IJAERS)*, 2016
12. R. K. Abhilash, Design and Development of a Low-Cost Smart Agriculture System, *International Conference on Innovations in Electrical, Electronics, Instrumentation, and Media Technology*, 2018

13. P. V. Prasanna, Agricultural Field Monitoring and Automation Using Wireless Sensors, *International Journal of Computer Applications*, 2015, 1-5.
14. Dinesh Kumar, Review on Precision Agriculture for Better Crop Production, *International Journal of Computer Applications*, 2015
15. M. A. Hossain, Development of a Smart Farming System for Monitoring and Controlling Environmental Conditions, *International Journal of Advanced Computer Science and Applications (IJACSA)*
16. Lowe, D. G., Distinctive Image Features from Scale-Invariant Key points, *International Journal of Computer Vision*, 60 (2), 2004, 91-110.
17. Dalal, N., & Triggs, B., Histograms of Oriented Gradients for Human Detection, *IEEE Conference on Computer Vision, and Pattern Recognition (CVPR)*, 2005.
18. Liu, C., Yuen, J., & Torralba, A SIFT Flow: Dense Correspondence across Scenes and its Applications. *IEEE Transactions on Pattern Analysis and Machine Intelligence*, 33(5), 2011.
19. Girshick, R., Donahue, J., Darrell, T., & Malik, Rich feature hierarchies for accurate object detection and semantic segmentation, *IEEE Conference on Computer Vision, and Pattern Recognition*, 2014.
20. He, K., Zhang, X., Ren, S., & Sun, J., Deep Residual Learning for Image Recognition, *IEEE Conference on Computer Vision, and Pattern Recognition (CVPR) 2016*.
21. Redmon, J., Divvala, S., Girshick, R., & Farhadi, You Only Look Once: Unified, Real-Time Object Detection, *IEEE Conference on Computer Vision, and Pattern Recognition (CVPR)*, 2016.
22. Zhang, H., Xu, T., Li, H., Zhang, S., Wang, X., Huang, X., & Metaxas, D. N., StackGAN++: Realistic Image Synthesis with Stacked Generative Adversarial Networks, *IEEE Transactions on Pattern Analysis and Machine Intelligence*, 99, 2018.
23. Kirtan Jha, Aalap Doshi, Poojan Patel, Manan Shah, A comprehensive review on automation in agriculture using artificial intelligence, *Artificial Intelligence in Agriculture*, 2, 2019, 1-12
24. Manas Wakchaure, B.K. Patle, A.K. Mahindrakar, Application of AI techniques and robotics in agriculture: A review, *Artificial Intelligence in the Life Sciences*, 3, 2023, 100057
25. Zulfiqar Ali, Asif Muhammad, Nangkyeong Lee, Muhammad Waqar, Seung Won Lee, Artificial Intelligence for Sustainable Agriculture: A Comprehensive Review of AI-Driven Technologies in Crop Production, *Sustainability* 2025, 17(5), 2281; <https://doi.org/10.3390/su17052281>
26. Ahmed AMIN, Xiaochan WANG, Yongnian ZHANG, Li TIANHUA, Yanyu CHEN, Jinming ZHENG, Yinyan SHI, Mahmoud A. ABDELHAMID, A Comprehensive Review of Applications of Robotics and Artificial Intelligence in Agricultural Operations, *Studies in Informatics and Control*, 32(4) 2023, 59-70.