

DESIGN AND IMPLEMENTATION OF HALF-BRIDGE INVERTER TOPOLOGIES TO COOKER INDUCTION HEATING

Parimal S. Bhambare^{1*}, Abdulbary Abubaker Zein AlZubaidi²

^{1,2} National University of Science and Technology, Muscat, Sultanate of Oman

Abstract

An induction cooker is a process of inductive electrical heating using induction material. This technology is called electromagnetic induction. This induction cooker is based on the electromagnetic induction principle. The induction cooks on top using households, and this application become in demand in the market and increasingly accepted as useful, energy-saving, and efficient is good for preparing food. It has useful benefits for induction cookers, including better efficiency, safety, and heating speed. The induction cooker is designed and tested for different power outputs with varying frequencies.

1. Introduction

The high efficiency, cleanliness, safety, and performance, the induction cooker is a well-known and widely used cooking technology throughout professional and residential settings. But in recent

Received:30.04.2024; Accepted: 08.06.2024

Keywords: Induction cooker, Electrical heating, Inverter

*Corresponding author name and email: Parimal S. Bhambare, Parimalbhambare@nu.edu.om

How to cite this article: Parimal S. Bhambare, Abdulbary Abubaker Zein AlZubaidi, Design, and implementation of half bridge inverters topologies to cooker induction heating, KT Journal of Mechanical Engineering, 1, 2024, 1-8. <https://doi.org/10.64188/3048956325001>

years, the technology has evolved considerably [1]. Due to its recent increase in importance in industry and technology, induction heating has been used for an array of purposes, including melting metals, soldering, and surface hardening. Induction cookers are a single instance of a home appliance that employs this type of technology. These are two physical aspects of induction heating: Magnetic hysteresis is a method that employs an external magnetic field generated by a ferromagnetic material [2].

Heat losses occur due to atomic dipoles attaching themselves to the magnetic field. Induced Currents: When exposed to a fluctuating magnetic field, a conductive body behaves similarly to a conducting loop, producing eddy currents, which are electrical currents that travel through the conductor. The conductor itself may be warmed by joules thanks to these eddy currents. Developing an induction cooker that incorporates a half-bridge inverter is the primary objective of the current endeavor. In simple terms, the aim is to utilize a microcontroller that controls the power provided to the induction coil and pot so that it can inductively heat the pot for cooking and vary its temperature. They tested the instrument at 50V DC 1 kW following the development of the microcontroller software and half-bridge inverter [3].

2. Materials and Methods

All three main elements of a home-supply induction cooker include a converter circuit, an induction coil, and an oven surface or metal. The blocks in the diagram shown above demonstrate how the mains voltage is filtered and rectified to generate a DC bus. The inducing coil obtains a variable frequency supplied by the resonant inverter, which can vary between 30 kHz to 65 kHz. An alternating magnetic field is created by this changing current. The pot's base warmed because of magnetic hysteresis and eddy current brought on by the magnetic current [4].

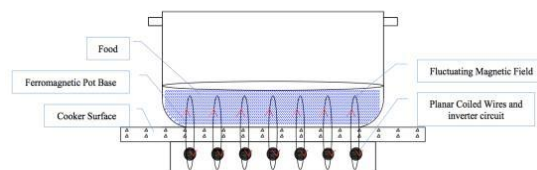

Figure 1. Induction cooker

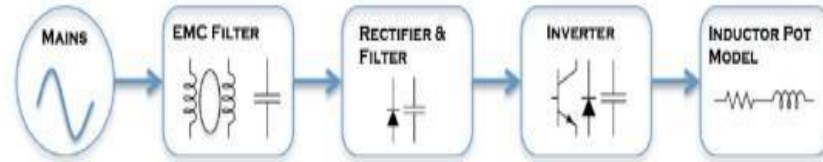

Figure 2. Block diagram of induction cooker hub

2.1 Data analysis

The first step in the project is to identify the device's attributes, including the parabolic design, mirror movement, motor, and desired sensor. To be certain each stage and method is planned effectively, the flow chart is important. Energy losses exist in all circuit concepts, especially when a resistor is included. To decrease the power losses in the resistor whilst switching, a snubber capacitor is added to the circuit.

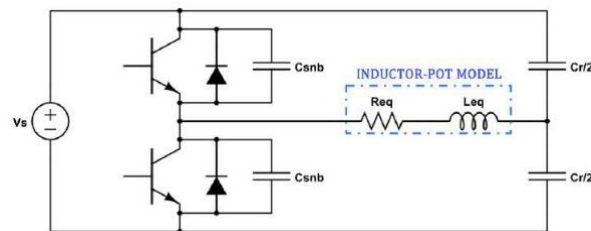

Figure 3. Half-bridge resonant inverter

2.2 Design a half-bridge inverter

Two essential designs are required for evaluating the circuits and components required to create a half-bridge inverter [5]. Resonance happens in a half-bridge circuit, which includes an RLC, whereby the inductor's unseen magnetic field generates an electric current in the winding that charges the capacitor. The electric current generated from the inductor's magnetic field is carried by the discharging capacitor. If the formula that follows can be employed to figure out the circuit's resonant frequency (f_r): resonance happens if the impedance is solely resistive at the resonant frequency (f_r) and the capacitive and inductor responses converge for the given amounts of inductance and capacitance [6].

2.3 Circuit Characteristics

Power output (Ph) for harmonic in the inverter is calculated by Fourier Transform as below where Ih as current, voltage Vh, and Zh as circuit impedance [7-8].

$$P_h = V_{h \text{ rms}} \times I_{h \text{ rms}} \quad (1)$$

$$I_{h \text{ rms}} = (V_{h \text{ rms}}) / Z_h \quad (2)$$

If the circuit's resonant frequency (fr) is determined by the subsequent equation, its impedance is solely resistive at this frequency and the capacitive and inductive responses remain the same [9-11].

$$f_r = 1 / (2\pi\sqrt{LC}) \quad (3)$$

3. Results and Discussion

Four fundamental circuits needed to be built for the inductor cooker implementation. To reduce the elevated voltages entering the inverter, the microcontroller delivers a signal to the optoisolator. That amplification mechanism in the IGBT gates produces AC across the coil, and the driver circuit will therefore increase its voltage signal whilst keeping the current without overdrawing, which might damage the circuit components. The main elements of this project's circuit design include an Arduino Uno controller, an optoisolator circuit, a driver circuit, and a half-bridge circuit.

3.1 Circuit Microcontroller

There can be something incorrect about this project's use of the Adriano microcontroller. For the user to pick the power level to observe the LCD, the microcontroller must generate a high-frequency switching signal. Three different types of microcontrollers can be employed for developing this circuit, although the Arduino Uno is preferred because it is affordable and easy to set up. PSpice was utilized to program the signal; each pulse was initially separated from the half-bridge circuit and created separately. Transistors are excellent components; Thus, they do not need for driver circuits to serve as gates. Arduino is supplied by a 12V DC power input. The LCD is powered by a 5V pin and connected to pin signal 6. A potentiometer may be employed to regulate the LCD's brightness. rather than the more customary signal and ground, the output signal is routed to the optoisolator using 5V and pin 5, the signal pin. The functioning power is measured by either pin 8, 9, or 10 to obtain a high signal.

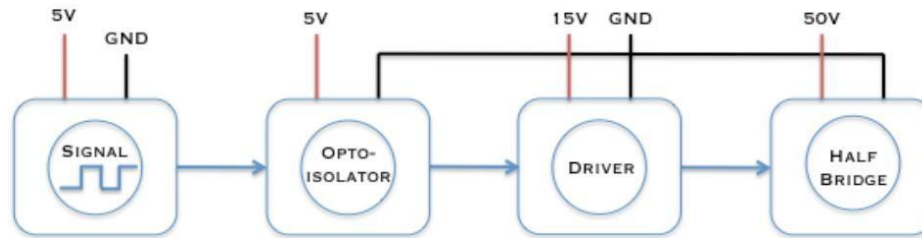

Figure 4. Complete circuit block diagram

4.2 Optoisolator Circuit

The optoisolator is a divider circuit that separates the device's low signal voltages from its high signal stages. It can be protected from hazardous excesses in different parts of the circuit using an optoisolator circuit control circuit. Infrared light, such instance, flows through a dielectric channel receiver before it is received and changed back into an electric signal. That enables the return electric signal to securely pass high voltage into the circuit. That is exactly the optoisolator functions.

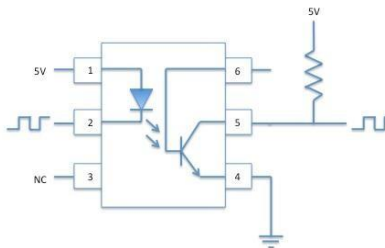

Figure 5. Opt isolator circuit

The barrier needs to be modified for each of the circuit's three switching frequencies. Whenever both resistances and frequency do not match effectively, the resultant waveform can decrease to a very low voltage, then the circuit can suffer physical harm. This will trigger the output voltage to drop below the minimum 3.3V necessary for the driver IC to identify it, or if the duty cycle is smaller than a perfect one half-bridge side stays in the on state longer than the other, significantly lowering the circuit's overall efficiency and reducing the life of its parts. The optimum design includes three potentiometers, each of which is connected to a distinct frequency and used by the user together with the power level display. The operation was achieved using a 6-pin switch, enabling the power level to be chosen without simultaneously flipping on the right potentiometer and maintaining isolation from the optoisolator. Unwanted potentiometers are prevented during the whole process using diodes.

4.3 Driver Circuit

The key objective of the driver circuit in the present endeavour is to allow the low-voltage and low-current signal to drive the IGBT gates via an optoisolator. IGBTs are known for having a capacitance gate that requires to be charged with electricity to be activated and released whenever it's time for it to disengage. More current traveling through the IGBT at the quickest rate can be turned on and off. A voltage greater than the IGBT collector voltage, which can range from 5 to 20 volts, is needed to turn on the MOSFET. The pin (Vs) provides the offset voltage from the IGBT's emitter, resulting in the voltage (Vcc). In this circuit, the higher side of the half-bridge takes (Vs) 50V and Vcc.

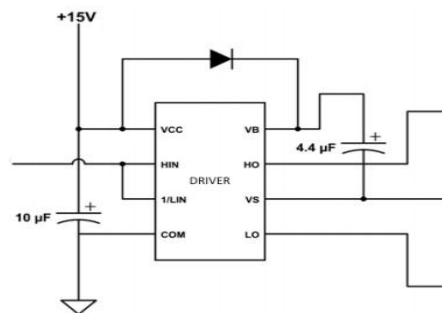

Figure 6. Driver circuit

4.4 Half Bridge Circuit

The IGBT's high and low ends will form a half-bridge in this project, which is going to be connected to a pot using resonant capacitors. What follows is an outline of why IGBT is preferred over MOSFET:

1. It offers a high voltage of up to 600V, and is usually used for inductor heating.
2. Since the switching frequency of this circuit is between 30 and 65 kHz, IGBT is the most appropriate choice. MOSFET will be used for switching frequencies that range between 300 kHz and 1 MHz.
3. IGBT is inexpensive and works adequately.

Sweetheart SGL160N60UFD Because of its low cost, quick switching, low conductor losses, and low switching opposition, IGBT was chosen for the half-bridge circuit because of its low cost and fast switching, low conductor losses, and low switching losses, and it has high input impedance.

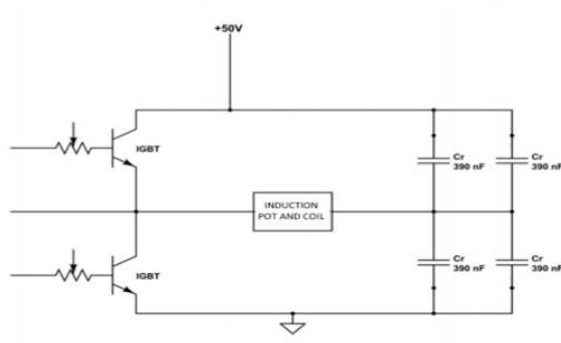

Figure 7. Half bridge circuits

Four 390 nF I utilized a single capacitor in the circuit instead of two 780nF capacitors because high-value capacitors frequently offer poor high frequency. On either side of the load, the resonance capacitor operates in parallel. To prevent ringing and fluctuations in voltage in the circuit, the inductively coupled transistor (IGBT) gate is hooked up in series to the driver signal and acts as a potentiometer. Therefore, when the IGBT turns on, the gate resistor regulates the ongoing current. The circuit's IGBT-related heat sink aims at discharging waste heat created when shifting into the environment. Between the IGBT and the sink is the conductivity thermal barrier, which consists of silicone rubber and film. This is meant to ensure the transfer of heat for metal conductivity.

4.7 Circuit Performance

The prototype of the induction cooker performed well and can produce some heat despite its relatively low input power; it can be noticed on the pod in Figure 8.



Figure 8. Half bridge circuits

5. Conclusions

The objective of this project was to employ the Half-Bridge topology to construct, control, and perform an induction heater. The developed prototype effectively, successfully, and progressively fulfils the requirement. To discover the most effective approaches, multiple ideas are looked at throughout the research stage. An interesting problem-solving approach that is extremely timely in an environment that is growing increasingly concerned regarding safety and reducing time and energy waste in everyday life is induction heating. Induction heating is most likely to become the norm when cooking in households in the future, given it is a step ahead of traditional cooking methods in all these areas.

Acknowledgments

Authors are thankful to Caledonian College for giving chance to use the facility for experimentation

References

1. J. A. Al., The domestic induction heating appliance. In Proc. *Appl Power Electron*, Conference, 12, 2008
2. Atherton, D. J., Theory of ferromagnetic hysteresis, *Journal of Magnetic and Magnetic Materials*, 1986
3. Coughin, C., Design Fundamentals of implementing an isolated half-bridge gate driver, Kennedy, 1, 2012, 1-5
4. Garcia, D. P., Reset observe and temperature control for induction hobs. Thesis, University of Zaragoza, 2011
5. Lopez-Nicolas, Reset observe and temperature control for induction hobs, Zaragoza: University of Zaragoza, 2011
6. Oscar Lucía, José M Burdío, Ignacio Millán, Jesús Acero, Luis A. Barragán, Efficiency oriented design of zvs half-bridge series resonant inverter with variable frequency duty cycle control, *IEEE Transaction on Power Electronics*, 1, 5-25
7. S. Llorente, F. M., A comparative study of resonant inverter topology used in induction, University of Zaragoza, 2011, 35-55
8. Zhang, R. Y., A generalized approach to planer induction heating magnetics, Massachusetts Institute of Technology, 2012.
9. Hung-I Hsieh, Chao-Chuan Kuo, Wei-Te Chang, Study of half-bridge series-resonant induction cooker powered by line rectified DC with less filtering, Industry Article, 2023. <https://doi.org/10.1049/pel2.12503>.
10. Metin Ozturk, A Simplified Design Method for Quasi-Resonant Inverter Used in Induction Hob, *Electronics* 2023, 12(19), 4145; <https://doi.org/10.3390/electronics12194145>

11. Vicente Esteve, José Jordán, Juan L. Bellido, Optimizing the Efficiency of Series Resonant Half-Bridge Inverters for Induction Heating Applications, *Electronics* 2025, 14(6), 1200; <https://doi.org/10.3390/electronics14061200>